

1222·2022  
**800**  
ANNI

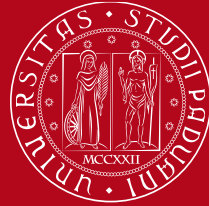

UNIVERSITÀ  
DEGLI STUDI  
DI PADOVA

# Optical and mechanical analysis and calibration of the EnVisS camera for the Comet Interceptor mission

Carmen Naletto - 39<sup>th</sup> Cycle

Supervisor: Dr. Vania Da Deppo

Co-supervisor: Prof. Mirco Zaccariotto

Dr. Paola Zuppella

Admission to the second year - 16/09/2024



- Comet Interceptor is the first Fast mission designed by ESA
- Scientific task:** interception and exploration of a Dynamically New Comet to gain information about the target's morphology, composition and plasma environment.

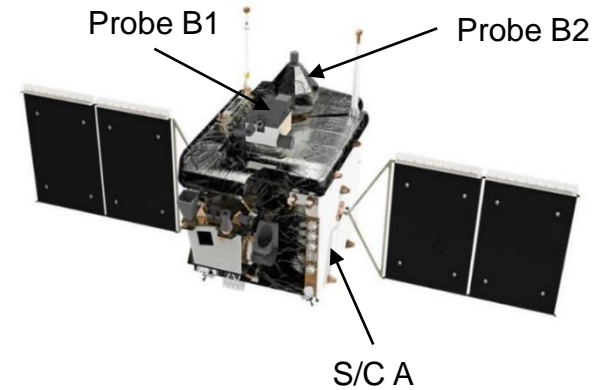

Comet Interceptor design concept (credit ESA)

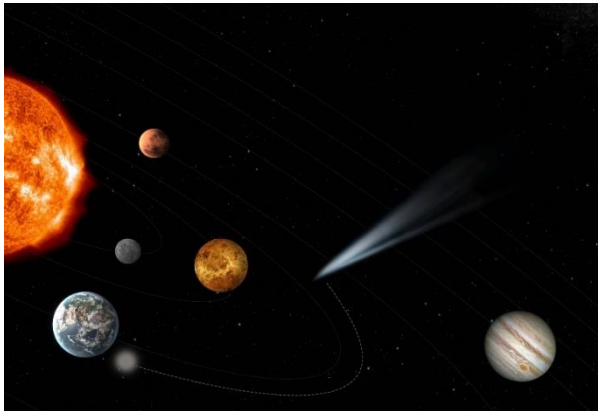

Carmen Naletto

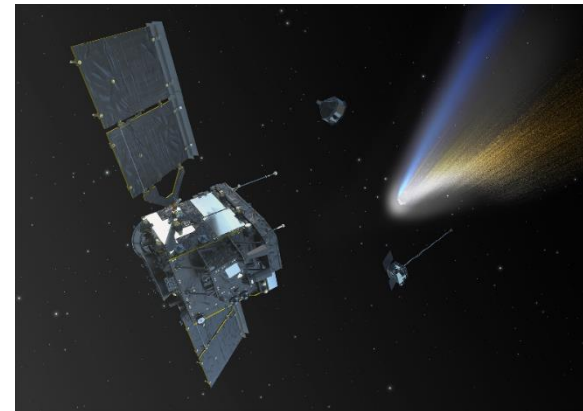

Optical and mechanical analysis and calibration of the EnVisS camera for the Comet Interceptor mission 2

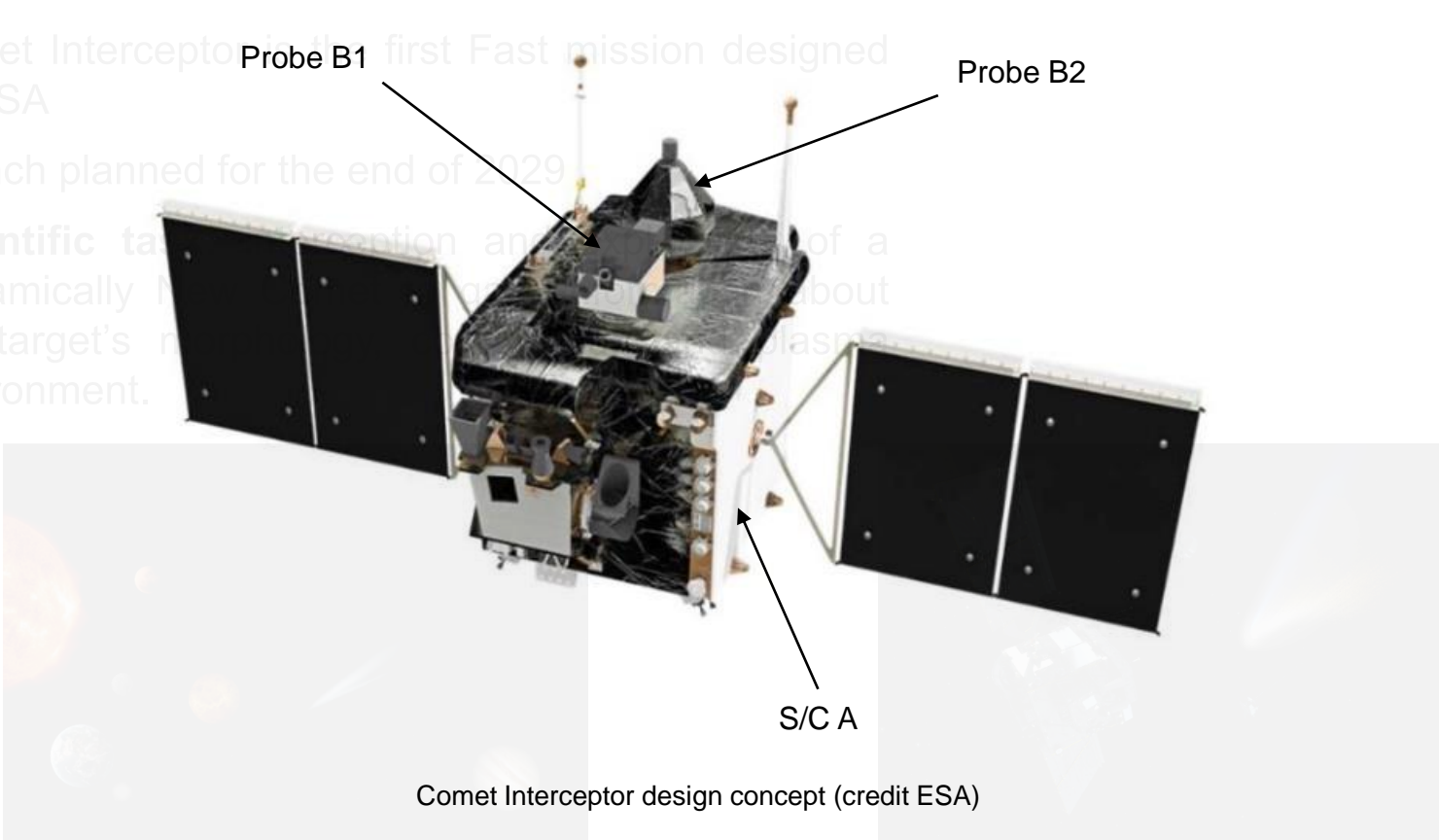

Comet Interceptor design concept (credit ESA)

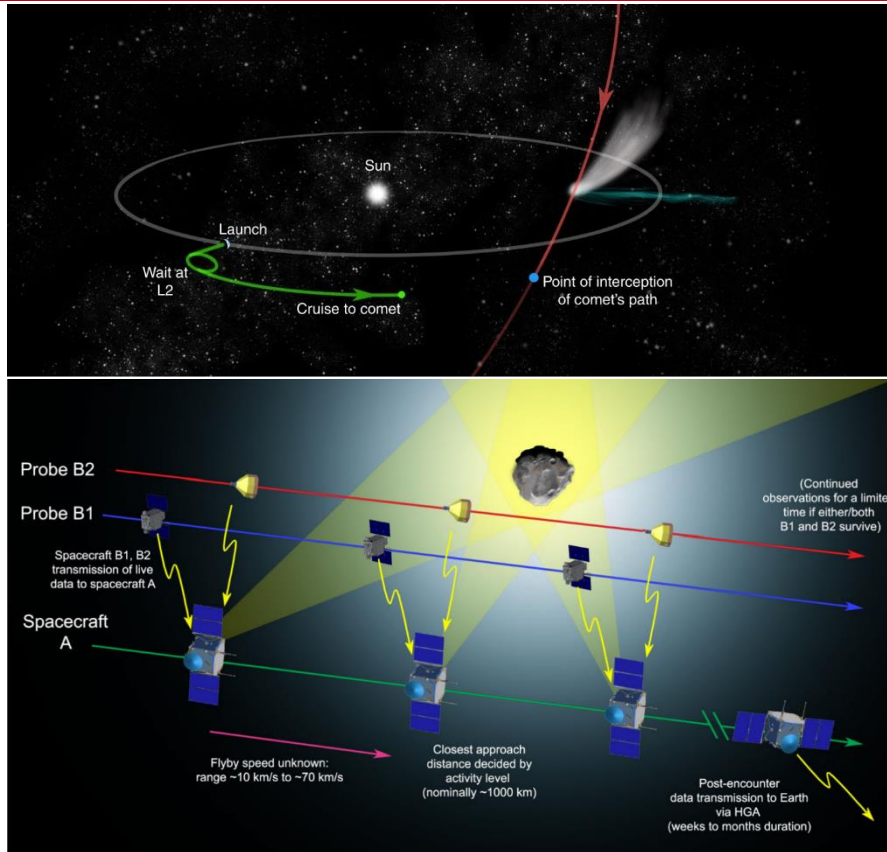

Mission analysis configuration sketch (credit ESA)

- Launch planned for the end of 2029
- Direct transfer to the Sun-Earth Lagrange Point SEL2, where the mission will wait until a potential target is found
- When close to the target, the mission will separate into three modules: S/C A will keep its distance from the comet (1000 km), while B1 and B2 will get closer to the celestial object (800 km and 400 km, respectively).
- The remote sensing instruments aboard all three platforms will allow simultaneous observations from multiple points, thus creating a 3D profile of the chosen object.

- The EnVisS (Entire Visible Sky) camera is one of the optical instruments designed to perform remote sensing
- All-sky camera aboard of Probe B2
- **Scientific task:** mapping and studying the comet's coma in the visible range
- Principal components: optical head (10 lenses), Filter Strip Assembly (FSA), CMOS detector
- CNR-IFN is the scientific institution hosting the instrument Principal Investigator (Vania Da Deppo)

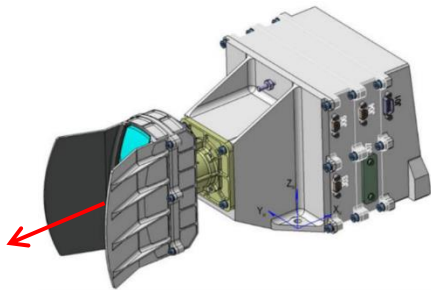

EnVisS 3D CAD model (credit LDO)

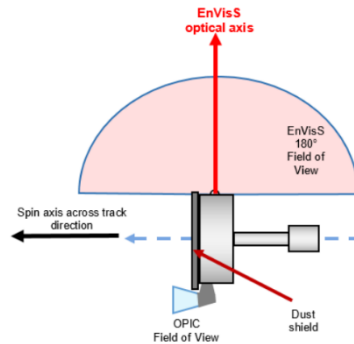

EnVisS placement on B2 and its static FoV

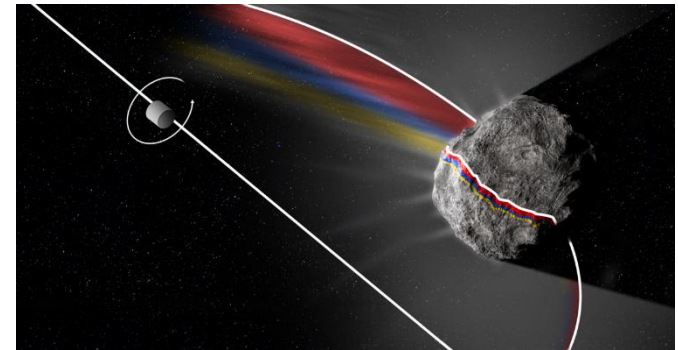

EnVisS dynamic FoV and B2 spinning motion

- Opto-mechanical characterization of the BreadBoard (BB) components of the EnVisS camera (collaboration with CNR-IFN)
  - Optical Head (OH)
  - Filter Strip Assembly (FSA)
- Realization of a detailed radiometric model for the EnVisS camera
- Tests and analysis on EnVisS Proto-Flight Model in collaboration with the Leonardo SpA team

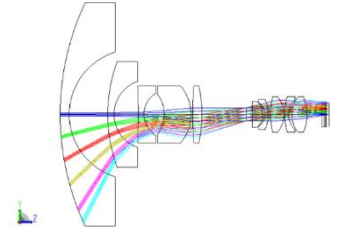
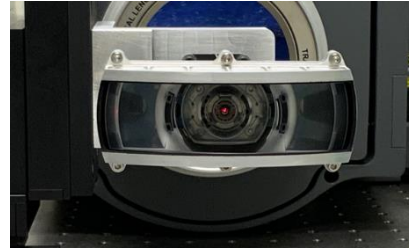

Picture of the EnVisS BB OH and ray-tracing along the optical head to the sensor (credit LDO)

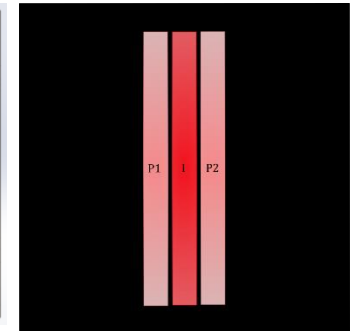
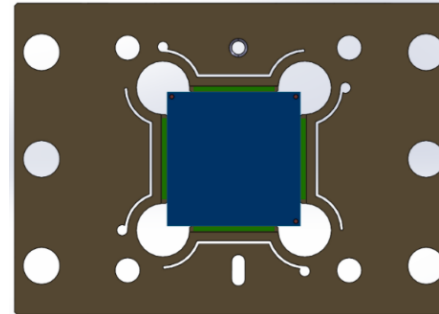

Schematic configuration of the FSA

- Opto-mechanical characterization of the BreadBoard (BB) components of the EnVisS camera (collaboration with CNR-IFN)
  - Optical Head (OH)
  - **Filter Strip Assembly (FSA)**

Experimental test in Leonardo SpA facilities: **verify the shear strength of the adhesive layers in the FSA**

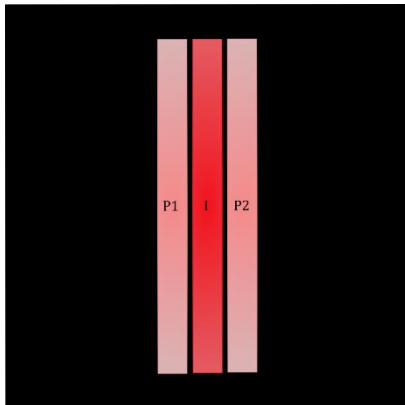

Schematic configuration of the FSA

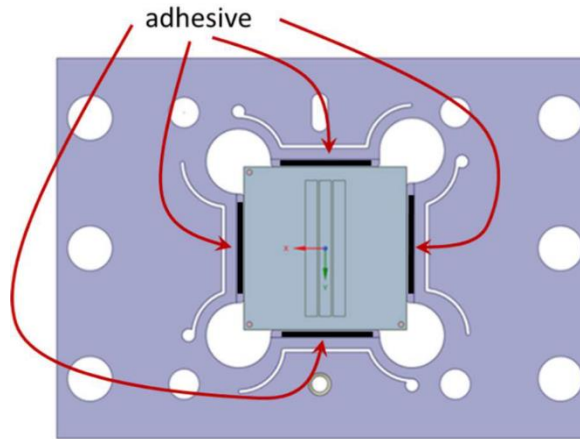

Schematic configuration of the FSA (credit LDO)

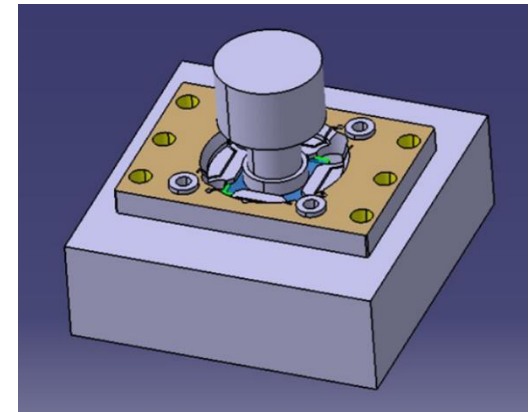

Shear test schematic configuration (credit LDO)

## Finite Element Analysis (Patran-Nastran)

Three main groups:

- supporting structure
- adhesive layers
- filters

Applied shear force:  $F = 1 \text{ N}$

**Goal:** find the maximum shear force to which the glue layers can be subjected without the system breaking

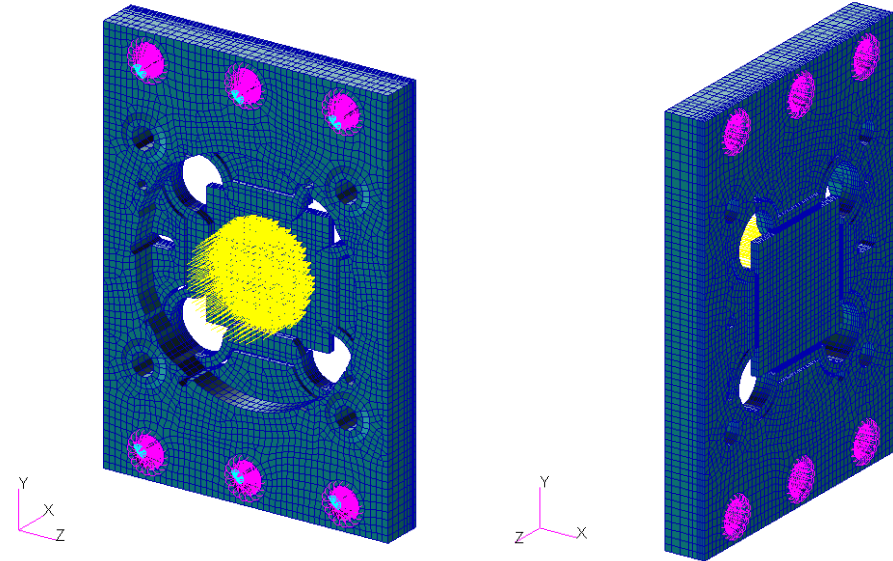

Finite Element Model representing the shear test

Adhesive Ec9323-2 B/A  $\rightarrow \tau_{max} = 30 \text{ MPa}$   
 Under a  $F = 1 \text{ N}$   $\rightarrow \tau_{XY\_max} = 0.04 \text{ MPa}$

**Linear Model**  $\rightarrow F_{max} = \frac{\tau_{max}}{\tau_{XY\_max}} F = 704.2 \text{ N}$

Aluminum 6082 T6  $\rightarrow \sigma_{max} = 290 \text{ MPa}$   
 Under a  $F = 1 \text{ N}$   $\rightarrow \sigma_{VM\_max} = 1.32 \text{ MPa}$

**Linear Model**  $\rightarrow F_{max} = \frac{\sigma_{max}}{\sigma_{VM\_max}} F = 219.7 \text{ N}$

**Supporting structure plastically deforms before the bonding zone is damaged**

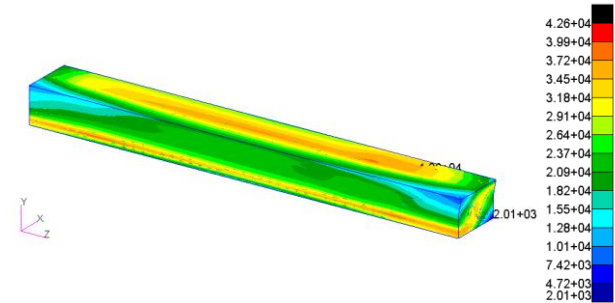

XY component of the stress tensor acting on one of the adhesive layers

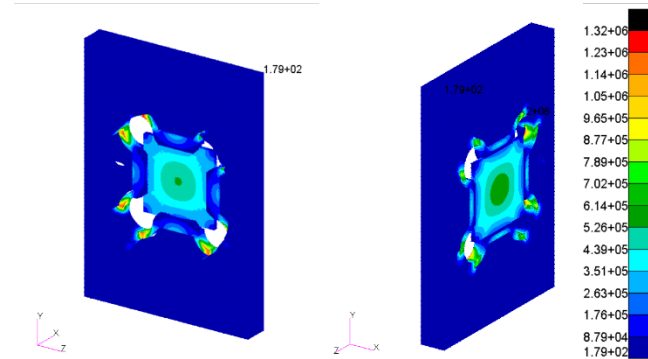

Von Mises stress distribution on the analyzed system

- Realization of a detailed radiometric model for the EnVisS camera
  - 1<sup>st</sup> step: realization of a simplified radiometric model

**Aim:** better understand the value of the incident signal on the camera's detector and so calculate the ratio of the signal in the operational bandwidth (550-800 nm) to that outside this range (350-550 nm and 800-1100 nm).

The signal evaluation has been performed considering:

- solar irradiance
- transmission of the ten lenses composing EnVisS optical head, of the BroadBand filter and of the D263 Cover Plain Glass of the detector;
- quantum efficiency (QE) of the detector

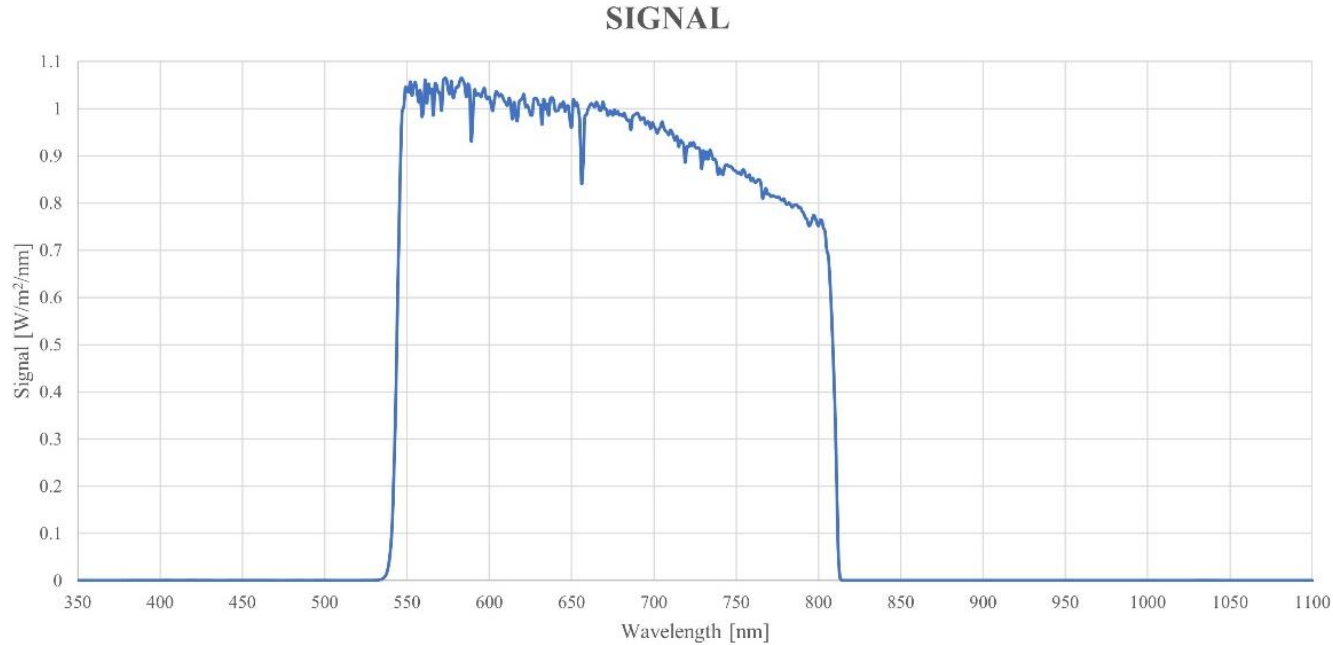

$$CR = \frac{\text{Signal (550 – 800 nm)}}{\text{Signal (350 – 550, 800 – 1100)}} = 14737,9$$

## ❑ Visiting student at IAA (October 2024 – March 2025)

Realization of a detailed radiometric model:

- Theoretical modelling to understand the impact of coma characteristics on EnVisS observations
- Simulation of the radiance of a cometary coma
- Simulations of the effects of coma characteristics on the radiance in the EnVisS study-case

## ❑ Opto-mechanical tests and simulations of the EnVisS BreadBoard (BB) optical head and filter strips

## ❑ Alignment Integration Test and Verification (AIT/AIV) of the PFM (collaboration with LDO)



- Carmen Naletto, Paolo Chioetto, Simone Nordera, Mirco Zaccariotto, Paola Zuppella and Vania Da Deppo; “Characterization of the polarizing filters for the EnVisS camera”, Space Telescopes and Instrumentation 2024: Optical, Infrared, and Millimeter Wave, Volume 13092, 12 pages + poster, Event: SPIE Astronomical Telescopes + Instrumentation, 2024, Yokohama, Japan. <https://doi.org/10.1117/12.3021121>
- Vania Da Deppo, Paola Zuppella, Vincenzo Della Corte, Enrico Friso, Simone Nordera, Fabio Frassetto, Lorenzo Cocola, Paolo Chioetto, Carmen Naletto, Claudio Pernechele; “Setting up a laboratory test bench for optical verification and testing of the EnVisS camera prototype”, Space Telescopes and Instrumentation 2024: Optical, Infrared, and Millimeter Wave, Volume 13092, 8 pages + poster, Event: SPIE Astronomical Telescopes + Instrumentation, 2024, Yokohama, Japan. <https://doi.org/10.1117/12.3021226>
- Lara, L. M., Gutiérrez, P., Castro Marin, J. M., Da Deppo, V., Della Corte, V., and Zuppella, P. and the EnVisS Team; “EnVisS camera for the Comet Interceptor mission (ESA-JAXA): polarimetric observations of cometary, Europlanet Science Congress 2024, Berlin, Germany, 8–13 Sep 2024, EPSC2024-1259, <https://doi.org/10.5194/epsc2024-1259>, 2024. Oral presentation.
- Da Deppo, V., Della Corte, V., Zuppella, P., Lara, L. M., Castro, J. M., and Gutierrez, P. J. and the EnVisS Team; “The Entire Visible Sky (EnVisS) instrument for the Comet Interceptor ESA mission: an update”, Europlanet Science Congress 2024, Berlin, Germany, 8–13 Sep 2024, EPSC2024-1307, <https://doi.org/10.5194/epsc2024-1307>, 2024. Poster presentation.
- Carmen Naletto, Paola Zuppella, Lara Senter, Simone Nordera, Mirco Zaccariotto, Beatrice Tofani, Riccardo Gabrieli, Lorenzo Guido Fiocco, Vincenzo Della Corte, Vania Da Deppo; “Characterization measurements for the realization of the filter strip assembly of the enviss camera”; accepted abstract (oral presentation and paper) for the ICSO 2024 (21 - 25 October | Antibes Juan-les-Pins, France) conference.
- Vania Da Deppo, Lara Senter, Vincenzo Della Corte, Paola Zuppella, Luisa M. Lara, José M. Castro, Pedro J. Gutierrez, Lorenzo G. Fiocco, Alessandro Alimenti, Beatrice Tofani, Riccardo Gabrieli, Giuseppe Impiccihé, Michele Dami, Leonardo Tommasi, Fulvia Verzegnassi, Ignacio Martinez-Navajas, Carmen Naletto, Paolo Chioetto, Lorenzo Cocola, Fabio Frassetto, Jaime Jimenez, Alvaro Mazuecos, Ivano Bertini, Marco Fulle, Cecilia Tubiana, Alessandra Rotundi, Juan-Carlos Gomez, Daniel Guirado, Fernando Moreno, Olga Muñoz, Stefano Bagnulo, Geraint Jones, and Jaan Praks; “THE ENVISS FISH-EYE CAMERA FOR THE COMET INTERCEPTOR ESA MISSION: DESIGN AND PERFORMANCE”, accepted abstract (poster and paper) for the ICSO 2024 (21 - 25 October | Antibes Juan-les-Pins, France) conference.
- Vania Da Deppo, Vincenzo Della Corte, Paola Zuppella, Luisa Lara, José M. Castro Marin, Pedro Gutierrez, EnVisS Team; “ENVISS: THE ENTIRE-VISIBLE-SKY CAMERA FOR THE COMET INTERCEPTOR ESA MISSION”, poster, 45th COSPAR Scientific Assembly 2024.



# Thanks for the attention

1222 • 2022  
**800**  
ANNI



UNIVERSITÀ  
DEGLI STUDI  
DI PADOVA